

## Features

- Complete device family with logic densities of 300 to 900 usable gates (see [Table 1](#))
- Device erasure and reprogramming with advanced, non-volatile EPROM configuration elements
- Fast pin-to-pin logic delays as low as 10 ns and counter frequencies as high as 100 MHz
- 24 to 68 pins available in dual in-line package (DIP), ceramic and plastic J-lead chip carrier (JLCC and PLCC), pin-grid array (PGA), and small-outline integrated circuit (SOIC) packages
- Programmable security bit for protection of proprietary designs
- 100% generically tested to provide 100% programming yield
- Programmable registers providing D, T, JK, and SR flipflops with individual clear and clock controls
- Software design support featuring the Altera® MAX+PLUS® II development system on 486- and Pentium-based PCs, and Sun SPARCstation, HP 9000 Series 700/800, and IBM RISC System/6000 workstations, and third-party development systems
- Programming support with Altera's Master Programming Unit (MPU); programming hardware from Data I/O, BP Microsystems, and other third-party programming vendors
- Additional design entry and simulation support provided by EDIF, library of parameterized modules (LPM), Verilog HDL, VHDL, and other interfaces to popular EDA tools from manufacturers such as Cadence, Exemplar Logic, Mentor Graphics, OrCAD, Synopsys, Synplicity, and VeriBest

Feature	EP610 EP610I	EP910 EP910I	EP1810
Usable gates	300	450	900
Macrocells	16	24	48
Maximum user I/O pins	22	38	64
t <sub>PD</sub> (ns)	10	12	20
f <sub>CNT</sub> (MHz)	100	76.9	50

## General Description

The Altera Classic™ device family offers a solution to high-speed, low-power logic integration. Fabricated on advanced CMOS technology, Classic devices also have a Turbo-only version, which is described in this data sheet.

Classic devices support 100% TTL emulation and can easily integrate multiple PAL- and GAL-type devices with densities ranging from 300 to 900 usable gates. The Classic family provides pin-to-pin logic delays as low as 10 ns and counter frequencies as high as 100 MHz. Classic devices are available in a wide range of packages, including CerDIP, PDIP, PLCC, PGA, and SOIC packages.

EPROM-based Classic devices can reduce active power consumption without sacrificing performance. This reduced power consumption makes the Classic family well suited for a wide range of low-power applications. Classic devices are 100% generically tested and can be erased with ultra-violet (UV) light, allowing design changes to be implemented quickly.

Classic devices use sum-of-products logic and a programmable register. The sum-of-products logic provides a programmable-AND/fixed-OR structure that can implement logic with up to eight product terms. The programmable register can be individually programmed for D, T, SR, or JK flipflop operation or can be bypassed for combinatorial operation. In addition, macrocell registers can be individually clocked either by a global clock or by any input or feedback path to the AND array. Altera's proprietary programmable I/O architecture allows the designer to program output and feedback paths for combinatorial or registered operation in both active-high and active-low modes. These features make it possible to implement a variety of logic functions simultaneously.

Classic devices are supported by Altera's MAX+PLUS II development system, a single, integrated package that offers schematic, text—including VHDL, Verilog HDL, and the Altera Hardware Description Language (AHDL)—and waveform design entry; compilation and logic synthesis; simulation and timing analysis; and device programming. The MAX+PLUS II software provides EDIF 2.0.0 and 3.0.0, LPM, VHDL, Verilog HDL, and other interfaces for additional design entry and simulation support from other industry-standard PC- and workstation-based EDA tools. The MAX+PLUS II software runs on 486- and Pentium-based PCs, and Sun SPARCstation, HP 9000 Series 700/800, and IBM RISC System/6000 workstations. These devices also contain on-board logic test circuitry to allow verification of function and AC specifications during standard production flow.



For more information, go to the *MAX+PLUS II Programmable Logic Development System & Software Data Sheet* in this data book.

# Functional Description

The Classic architecture includes the following elements:

- Macrocells
- Programmable registers
- Output enable/clock select
- Feedback select

## Macrocells

Classic macrocells, shown in [Figure 1](#), can be individually configured for both sequential and combinatorial logic operation. Eight product terms form a programmable-AND array that feeds an OR gate for combinatorial logic implementation. An additional product term is used for asynchronous clear control of the internal register; another product term implements either an output enable or a logic-array-generated clock. Inputs to the programmable-AND array come from both the true and complement signals of the dedicated inputs; feedbacks from I/O pins that are configured as inputs; and feedbacks from macrocell outputs. Signals from dedicated inputs are globally routed and can feed the inputs of all device macrocells. The feedback multiplexer controls the routing of feedback signals from macrocells and from I/O pins. For additional information on feedback select configurations, see [Figure 3 on page 423](#).

**Figure 1. Classic Device Macrocell**

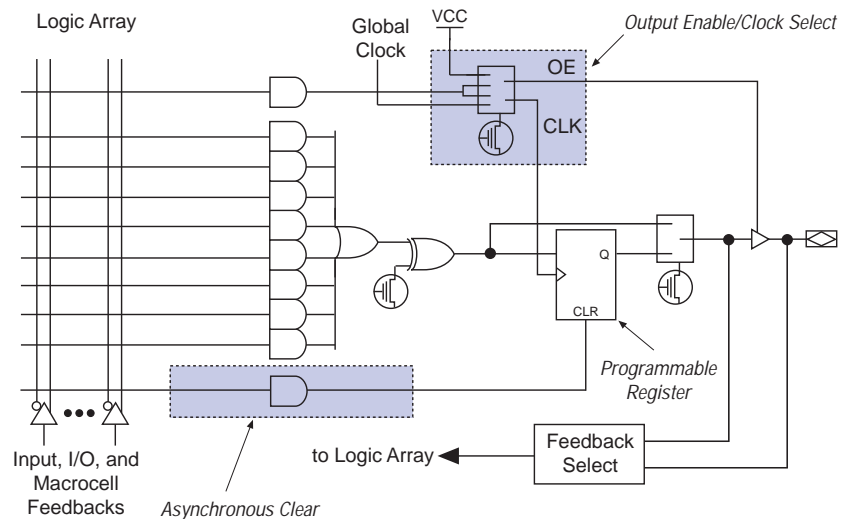

The eight product terms of the programmable-AND array feed the 8-input OR gate, which then feeds one input to an XOR gate. The other input to the XOR gate is connected to a programmable bit that allows the array output to be inverted. Altera's MAX+PLUS II software uses the XOR gate to implement either active-high or active-low logic, or De Morgan's inversion to reduce the number of product terms needed to implement a function.

### Programmable Registers

To implement registered functions, each macrocell register can be individually programmed for D, T, JK, or SR operation. If necessary, the register can be bypassed for combinatorial operation. During design compilation, the MAX+PLUS II software selects the most efficient register operation for each registered function to minimize the logic resources needed by the design. Registers have an individual asynchronous clear function that is controlled by a dedicated product term. These registers are cleared automatically during power-up.

In addition, macrocell registers can be individually clocked by either a global clock or any input or feedback path to the AND array. Altera's proprietary programmable I/O architecture allows the designer to program output and feedback paths for combinatorial or registered operation in both active-high and active-low modes. These features make it possible to simultaneously implement a variety of logic functions.

### Output Enable/Clock Select

Figure 2 shows the two operating modes (Modes 0 and 1) provided by the output enable/clock (OE/CLK) select. The OE/CLK select, which is controlled by a single programmable bit, can be individually configured for each macrocell. In Mode 0, the tri-state output buffer is controlled by a single product term. If the output enable is high, the output buffer is enabled. If the output enable is low, the output has a high-impedance value. In Mode 0, the macrocell flipflop is clocked by its global clock input signal.

In Mode 1, the output enable buffer is always enabled, and the macrocell register can be triggered by an array clock signal generated by a product term. This mode allows registers to be individually clocked by any signal on the AND array. With both true and complement signals in the AND array, the register can be configured to trigger on a rising or falling edge. This product-term-controlled clock configuration also supports gated clock structures.

**Figure 2. Classic Output Enable/Clock Select**

**Mode 0**

*In Mode 0, the register is clocked by the global clock signal. The output is enabled by the logic from the product term.*

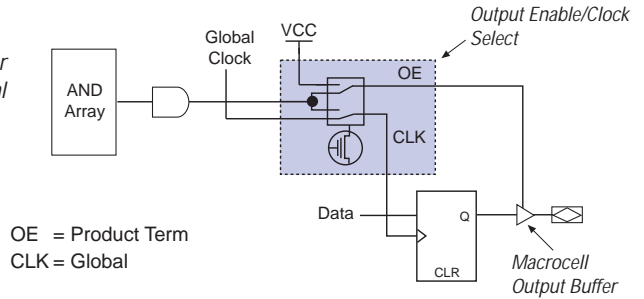

**Mode 1**

*In Mode 1, the output is permanently enabled and the register is clocked by the product term, which allows gated clocks to be generated.*

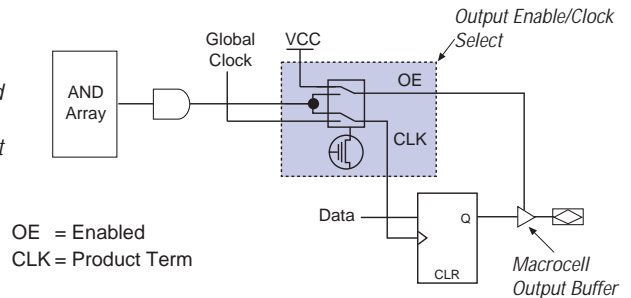

**Feedback Select**

Each macrocell in a Classic device provides feedback selection that is controlled by the feedback multiplexer. This feedback selection allows the designer to feed either the macrocell output or the I/O pin input associated with the macrocell back into the AND array. The macrocell output can be either the Q output of the programmable register or the combinatorial output of the macrocell. Different devices have different feedback multiplexer configurations. See [Figure 3](#).

**Figure 3. Classic Feedback Multiplexer Configurations**

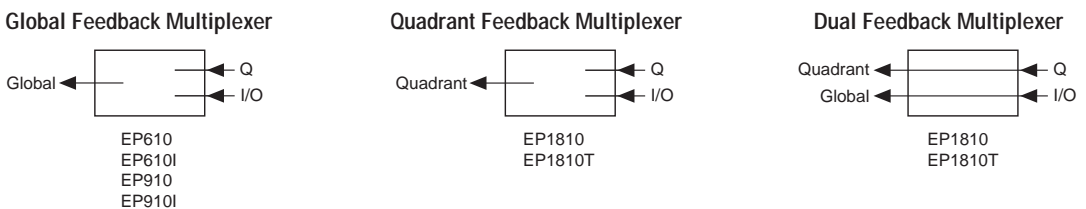

EP610, EP610I, EP910, and EP910I devices have a global feedback configuration; either the macrocell output (Q) or the I/O pin input (I/O) can feed back to the AND array so that it is accessible to all other macrocells.

EP1810 macrocells can have either of two feedback configurations: quadrant or dual. Most macrocells in EP1810 devices have a quadrant feedback configuration; either the macrocell output or I/O pin input can feed back to other macrocells in the same quadrant. Selected macrocells in EP1810 devices have a dual feedback configuration: the output of the macrocell feeds back to other macrocells in the same quadrant, and the I/O pin input feeds back to all macrocells in the device. If the associated I/O pin is not used, the macrocell output can optionally feed all macrocells in the device. In this case, the output of the macrocell passes through the tri-state buffer and uses the feedback path between the buffer and the I/O pin.

## Design Security

Classic devices contain a programmable security bit that controls access to the data programmed into the device. When this bit is programmed, a proprietary design implemented in the device cannot be copied or retrieved. This feature provides a high level of design security because data within EPROM configuration elements is invisible. The security bit that controls this function and other program data is reset only when the device is erased.

## Timing Model

Device timing can be analyzed with the MAX+PLUS II software, with a variety of popular industry-standard EDA simulators and timing analyzers, or with the timing model shown in Figure 4. Devices have fixed internal delays that allow the user to determine the worst-case timing for any design. The MAX+PLUS II software provides timing simulation, point-to-point delay prediction, and detailed timing analysis for system-level performance evaluation.

Figure 4. Classic Timing Model

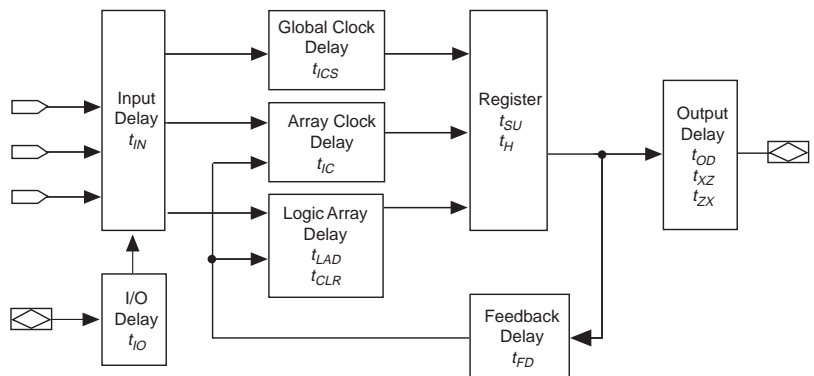

Timing information can be derived from the timing model and parameters for a particular device. External timing parameters represent pin-to-pin timing delays, and can be calculated from the sum of internal parameters. [Figure 5](#) shows the internal timing relationship for internal and external delay parameters.



For more information on device timing, refer to [Application Note 78 \(Understanding MAX 5000 & Classic Timing\)](#) in this data book.

Figure 5. Classic Switching Waveforms

$t_R$  and  $t_F < 3$  ns.  
 Inputs are driven at 3 V  
 for a logic high and  
 0 V for a logic low.  
 All timing characteristics  
 are measured at 1.5 V.

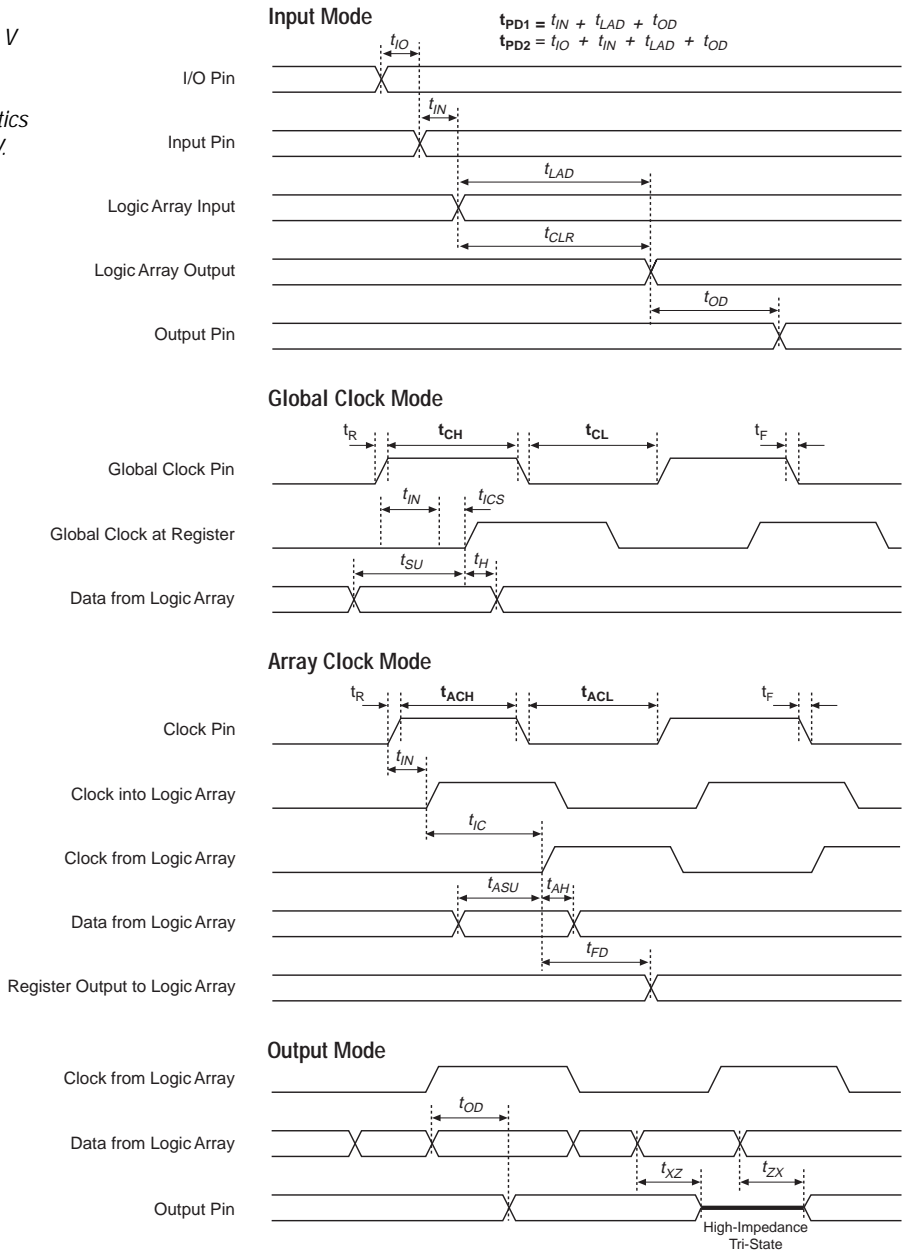



## Turbo Bit Option

Many Classic devices contain a programmable Turbo Bit™ option to control the automatic power-down feature that enables the low-standby-power mode. When the Turbo Bit option is turned on, the low-standby-power mode is disabled. All AC values are tested with the Turbo Bit option turned on. When the device is operating with the Turbo Bit option turned off (non-Turbo mode), a non-Turbo adder must be added to the appropriate AC parameter to determine worst-case timing. The non-Turbo adder is specified in the “AC Operating Conditions” tables for each Classic device that supports the Turbo mode.

## Generic Testing

Classic devices are fully functionally tested. Complete testing of each programmable EPROM configuration element and all internal logic elements before and after packaging ensures 100% programming yield. See [Figure 6](#) for AC test measurement conditions. These devices also contain on-board logic test circuitry to allow verification of function and AC specifications during standard production flow.

**Figure 6. AC Test Conditions**

*Power-supply transients can affect AC measurements. Simultaneous transitions of multiple outputs should be avoided for accurate measurement. Threshold tests must not be performed under AC conditions. Large-amplitude, fast ground-current transients normally occur as the device outputs discharge the load capacitances. When these transients flow through the parasitic inductance between the device ground pin and the test system ground, significant reductions in observable noise immunity can result.*

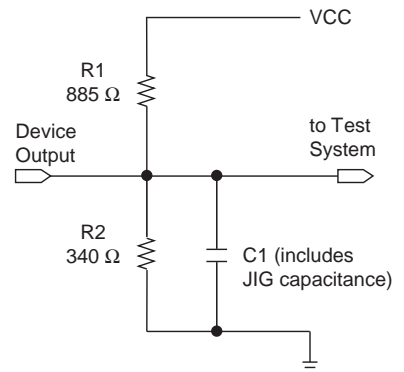

## Device Programming

Classic devices can be programmed on 486- and Pentium-based PCs with the MAX+PLUS II Programmer, an Altera Logic Programmer card, the Master Programming Unit (MPU), and the appropriate device adapter. The MPU performs continuity checking to ensure adequate electrical contact between the adapter and the device.

Data I/O, BP Microsystems, and other programming hardware manufacturers also offer programming support for Altera devices. See [Programming Hardware Manufacturers](#) in this data book for more information.



*Notes:*

## Features

- High-performance, 16-macrocell Classic EPLD
  - Combinatorial speeds with  $t_{PD}$  as fast as 10 ns
  - Counter frequencies of up to 100 MHz
  - Pipelined data rates of up to 125 MHz
- Programmable I/O architecture with up to 20 inputs or 16 outputs and 2 clock pins
- EP610 and EP610I devices that are pin-, function-, and programming file-compatible
- Programmable clock option for independent clocking of all registers
- Macrocells individually programmable as D, T, JK, or SR flipflops, or for combinatorial operation
- Available in the following packages (see [Figure 7](#)):
  - 24-pin small-outline integrated circuit (plastic SOIC only)
  - 24-pin ceramic and plastic dual in-line package (CerDIP and PDIP)
  - 28-pin plastic J-lead chip carrier (PLCC)

Figure 7. EP610 Package Pin-Out Diagrams

Package outlines not drawn to scale. Windows in ceramic packages only.

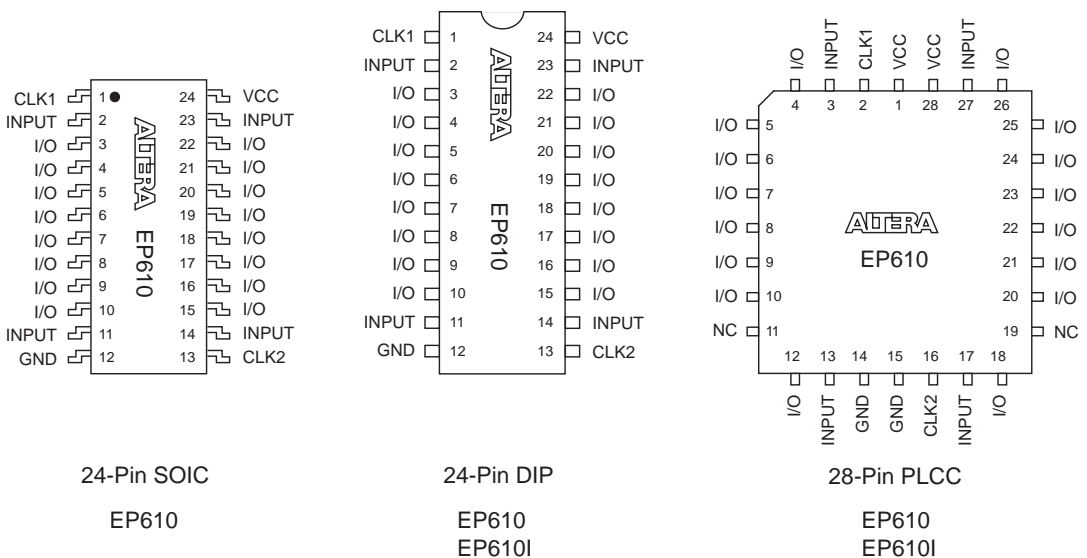

# General Description

EP610 devices have 16 macrocells, 4 dedicated input pins, 16 I/O pins, and 2 global clock pins (see [Figure 8](#)). Each macrocell can access signals from the global bus, which consists of the true and complement forms of the dedicated inputs and the true and complement forms of either the output of the macrocell or the I/O input. The CLK1 signal is a dedicated global clock input for the registers in macrocells 9 through 16. The CLK2 signal is a dedicated global clock input for registers in macrocells 1 through 8.

Figure 8. EP610 Block Diagram

Numbers without parentheses are for DIP and SOIC packages. Numbers in parentheses are for J-lead packages.

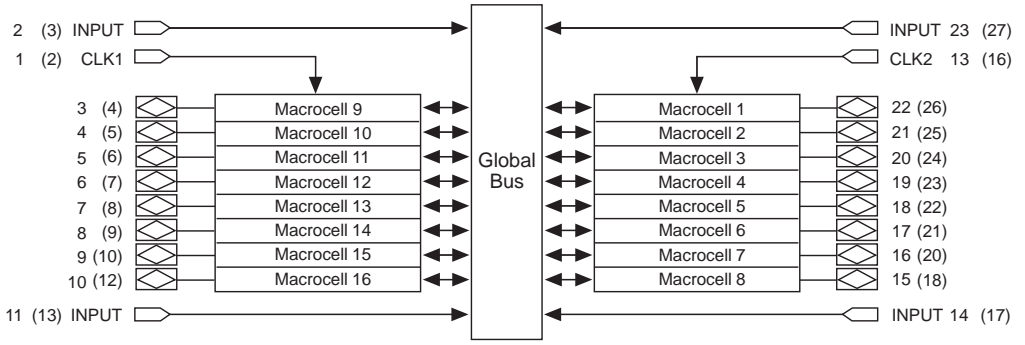

Figure 9 shows the typical supply current ( $I_{CC}$ ) versus frequency of EP610 devices.

Figure 9.  $I_{CC}$  vs. Frequency of EP610 Devices

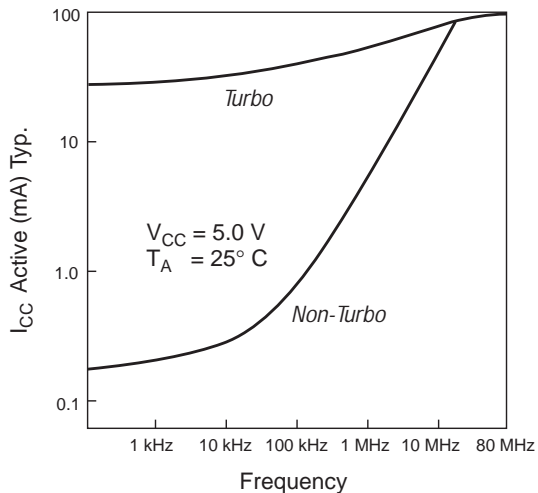
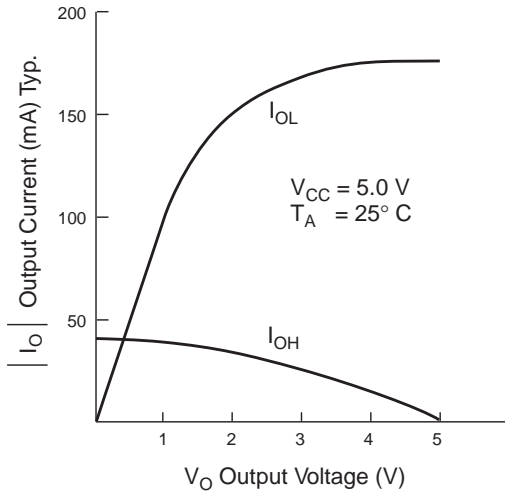

Figure 10 shows the typical output drive characteristics of EP610 devices.

Figure 10. Output Drive Characteristics of EP610 Devices

Drive characteristics may exceed shown curves.

EP610-15 & EP610-20 EPLDs



EP610-25, EP610-30 & EP610-35 EPLDs

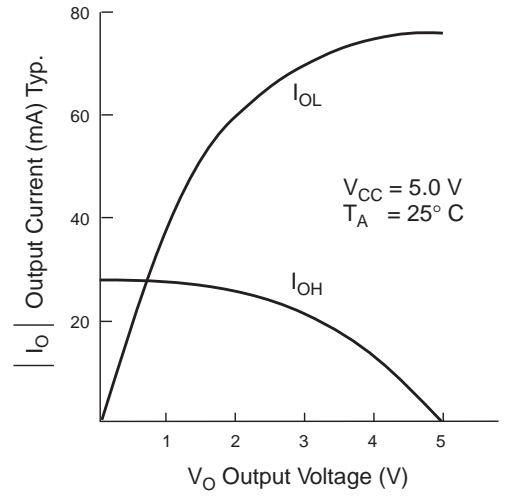

EP610I EPLDs

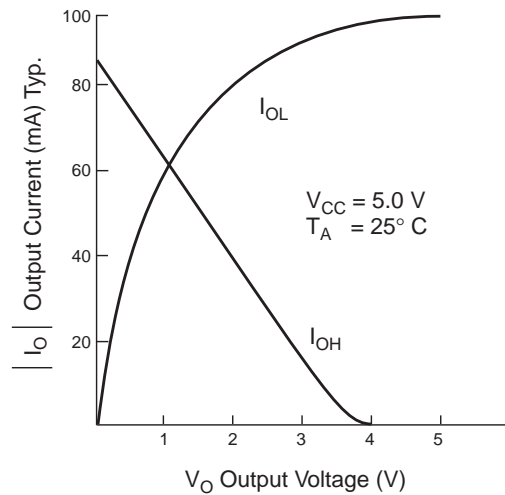

## Operating Conditions

The following tables provide information on absolute maximum ratings, recommended operating conditions, operating conditions, and capacitance for EP610 and EP610I devices.

### EP610 & EP610I Device Absolute Maximum Ratings *Notes (1), (2)*

Symbol	Parameter	Conditions	EP610		EP610I		Unit
			Min	Max	Min	Max	
V <sub>CC</sub>	Supply voltage	With respect to ground,	-2.0	7.0	-2.0	7.0	V
V <sub>I</sub>	DC input voltage	<i>Note (3)</i>	-2.0	7.0	-0.5	V <sub>CC</sub> + 0.5	V
I <sub>MAX</sub>	DC V <sub>CC</sub> or ground current		-175	175			mA
I <sub>OUT</sub>	DC output current, per pin		-25	25			mA
T <sub>STG</sub>	Storage temperature	No bias	-65	150	-65	150	°C
T <sub>AMB</sub>	Ambient temperature	Under bias	-65	135 (125)	-10	85	°C
T <sub>J</sub>	Junction temperature	Ceramic packages, under bias		150		150	°C
		Plastic packages, under bias		135		135	°C

### EP610 & EP610I Device Recommended Operating Conditions *Note (2)*

Symbol	Parameter	Conditions	EP610		EP610I		Unit
			Min	Max	Min	Max	
V <sub>CC</sub>	Supply voltage	<i>Note (5)</i>	4.75 (4.5)	5.25 (5.5)	4.75	5.25	V
V <sub>I</sub>	Input voltage		0	V <sub>CC</sub>	0	V <sub>CC</sub>	V
V <sub>O</sub>	Output voltage		0	V <sub>CC</sub>	0	V <sub>CC</sub>	V
T <sub>A</sub>	Operating temperature	For commercial use	0	70	0	70	°C
		For industrial use	-40	85	-40	85	°C
t <sub>R</sub>	Input rise time	<i>Note (6)</i>		100 (50)		500	ns
t <sub>F</sub>	Input fall time	<i>Note (6)</i>		100 (50)		500	ns

### EP610 & EP610I Device DC Operating Conditions *Note (4)*

Symbol	Parameter	Conditions	Min	Max	Unit
V <sub>IH</sub>	High-level input voltage		2.0	V <sub>CC</sub> + 0.3	V
V <sub>IL</sub>	Low-level input voltage		-0.3	0.8	V
V <sub>OH</sub>	High-level TTL output voltage	I <sub>OH</sub> = -4 mA DC, <i>Note (7)</i>	2.4		V
	High-level CMOS output voltage	I <sub>OH</sub> = -0.6 mA DC, <i>Notes (7), (8)</i>	3.84		V
V <sub>OL</sub>	Low-level output voltage	I <sub>OL</sub> = 4 mA DC, <i>Note (7)</i>		0.45	V
I <sub>I</sub>	I/O pin leakage current of dedicated input pins	V <sub>I</sub> = V <sub>CC</sub> or ground	-10	10	μA
I <sub>OZ</sub>	Tri-state output leakage current	V <sub>O</sub> = V <sub>CC</sub> or ground	-10	10	μA

**EP610 & EP610I Device Capacitance** *Note (9)*

			EP610		EP610I		
Symbol	Parameter	Conditions	Min	Max	Min	Max	Unit
C <sub>IN</sub>	Input pin capacitance	V <sub>IN</sub> = 0 V, f = 1.0 MHz		10		8	pF
C <sub>I/O</sub>	I/O pin capacitance	V <sub>OUT</sub> = 0 V, f = 1.0 MHz		12		8	pF
C <sub>CLK1</sub>	CLK1 pin capacitance	V <sub>IN</sub> = 0 V, f = 1.0 MHz		20		10	pF
C <sub>CLK2</sub>	CLK2 pin capacitance	V <sub>IN</sub> = 0 V, f = 1.0 MHz		20		12	pF

**EP610 Device I<sub>CC</sub> Supply Current** *Notes (2), (10)*

				EP610			
Symbol	Parameter	Conditions	Speed Grade	Min	Typ	Max	Unit
I <sub>CC1</sub>	V <sub>CC</sub> supply current (non-Turbo, standby)	V <sub>I</sub> = V <sub>CC</sub> or ground, no load, <i>Notes (11), (12)</i>			20	150	μA
I <sub>CC2</sub>	V <sub>CC</sub> supply current (non-Turbo, active)	V <sub>I</sub> = V <sub>CC</sub> or ground, no load, f = 1.0 MHz, <i>Notes (11), (12)</i>			5	10 (15)	mA
I <sub>CC3</sub>	V <sub>CC</sub> supply current (Turbo, active)	V <sub>I</sub> = V <sub>CC</sub> or ground, no load, f = 1.0 MHz, <i>Note (12)</i>	-15, -20		60	90 (115)	mA
			-25, -30, -35		45	60 (75)	mA

**EP610I Device I<sub>CC</sub> Supply Current** *Note (10)*

			EP610I			
Symbol	Parameter	Conditions	Min	Typ	Max	Unit
I <sub>CC1</sub>	V <sub>CC</sub> supply current (non-Turbo, standby)	V <sub>I</sub> = V <sub>CC</sub> or ground, no load, <i>Notes (11), (12)</i>		20	150	μA
I <sub>CC2</sub>	V <sub>CC</sub> supply current (non-Turbo, active)	V <sub>I</sub> = V <sub>CC</sub> or ground, no load, f = 1.0 MHz, <i>Notes (11), (12)</i>		3	8	mA
I <sub>CC3</sub>	V <sub>CC</sub> supply current (Turbo, active)	V <sub>I</sub> = V <sub>CC</sub> or ground, no load, f = 1.0 MHz, <i>Note (12)</i>		65	105	mA

### Notes to tables:

- (1) See the *Operating Requirements for Altera Devices Data Sheet* in this data book.
- (2) Numbers in parentheses are for industrial-temperature-range devices.
- (3) The minimum DC input is  $-0.3$  V. During transitions, the inputs may undershoot to  $-2.0$  V or overshoot to  $7.0$  V for periods less than  $20$  ns under no-load conditions.
- (4) These values are specified under the “[EP610 & EP610I Device Recommended Operating Conditions](#)” on page 432.
- (5) For EP610 devices, maximum  $V_{CC}$  rise time is  $50$  ms. For EP610I devices,  $V_{CC}$  rise time is unlimited with monotonic rise.
- (6) For EP610-15 and EP610-20 devices:  $t_R$  and  $t_F = 40$  ns.  
For EP610-15 and EP610-20 clocks:  $t_R$  and  $t_F = 20$  ns.
- (7) The  $I_{OH}$  parameter refers to high-level TTL or CMOS output current; the  $I_{OL}$  parameter refers to low-level TTL output current.
- (8) This parameter does not apply to EP610I devices.
- (9) The device capacitance is measured at  $25^\circ$  C and is sample-tested only. The clock-pin capacitance is for dedicated clock inputs only. For EP610-25, EP610-30, and EP610-35 devices: pin 13 has a maximum capacitance of  $50$  pF;  $C_{IN}$ ,  $C_{I/O}$ , and  $C_{CLK} = 20$  pF.
- (10) Typical values are for  $T_A = 25^\circ$  C and  $V_{CC} = 5$  V.
- (11) When the Turbo Bit option is not set (non-Turbo mode), EP610 devices enter standby mode if no logic transitions occur for  $100$  ns after the last transition. When the Turbo Bit option is not set, EP610I devices enter standby mode if no logic transitions occur for  $75$  ns after the last transition.
- (12) Measured with a device programmed as a 16-bit counter.



## EP610-15 &amp; EP610-20 Device AC Operating Conditions Notes (1), (2)

External Timing Parameters			EP610-15		EP610-20		Non-Turbo Adder	
Symbol	Parameter	Conditions	Min	Max	Min	Max	Note (3)	Unit
$t_{PD1}$	Input to non-registered output	$C1 = 35 \text{ pF}$		15		20	20	ns
$t_{PD2}$	I/O input to non-registered output	$C1 = 35 \text{ pF}$		17		22	20	ns
$t_{PZX}$	Input to output enable	$C1 = 35 \text{ pF}$		15		20	20	ns
$t_{PXZ}$	Input to output disable	$C1 = 5 \text{ pF}$ , Note (4)		15		20	20	ns
$t_{CLR}$	Asynchronous output clear time	$C1 = 35 \text{ pF}$		15		20	20	ns
$f_{MAX}$	Maximum clock frequency	Note (5)	83.3		62.5		0	MHz
$t_{SU}$	Global clock input setup time		9		11		20	ns
$t_H$	Global clock input hold time		0		0		0	ns
$t_{CH}$	Global clock high time		6		8		0	ns
$t_{CL}$	Global clock low time		6		8		0	ns
$t_{CO1}$	Global clock to output delay			11		13	0	ns
$t_{CNT}$	Global clock minimum period			12		16	0	ns
$f_{CNT}$	Maximum internal global clock frequency	Note (6)	83.3		62.5		0	MHz
$t_{ASU}$	Array clock input setup time		6		8		20	ns
$t_{AH}$	Array clock input hold time		6		8		0	ns
$t_{ACH}$	Array clock high time		7		9		0	ns
$t_{ACL}$	Array clock low time		7		9		0	ns
$t_{ODH}$	Output data hold time after clock	$C1 = 35 \text{ pF}$ , Note (7)	1		1		1	ns
$t_{ACO1}$	Array clock to output delay			15		20	20	ns
$t_{ACNT}$	Array clock minimum period			14		18	0	ns
$f_{ACNT}$	Array clock internal maximum frequency	Note (6)	71.4		55.6		0	MHz

Internal Timing Parameters			EP610-15		EP610-20		
Symbol	Parameter	Conditions	Min	Max	Min	Max	Unit
$t_{IN}$	Input pad and buffer delay			4		4	ns
$t_{IO}$	I/O input pad and buffer delay			2		2	ns
$t_{LAD}$	Logic array delay			6		11	ns
$t_{OD}$	Output buffer and pad delay	$C1 = 35 \text{ pF}$		5		5	ns
$t_{ZX}$	Output buffer enable delay	$C1 = 35 \text{ pF}$		5		5	ns
$t_{XZ}$	Output buffer disable delay	$C1 = 5 \text{ pF}$		5		5	ns
$t_{SU}$	Register setup time			5		4	ns
$t_H$	Register hold time			4		7	ns
$t_{IC}$	Array clock delay			6		11	ns
$t_{ICS}$	Global clock delay			2		4	ns
$t_{FD}$	Feedback delay			1		1	ns
$t_{CLR}$	Register clear time			6		11	ns

EP610-25, EP610-30 & EP610-35 AC Operating Conditions *Notes (1), (2)*

<i>External Timing Parameters</i>			EP610-25		EP610-30		EP610-35		Non-Turbo Adder	
Symbol	Parameter	Conditions	Min	Max	Min	Max	Min	Max	<i>Note (3)</i>	Unit
t <sub>PD1</sub>	Input to non-registered output	C1 = 35 pF		25		30		35	30	ns
t <sub>PD2</sub>	I/O input to non-registered output			27		32		37	30	ns
t <sub>PZX</sub>	Input to output enable			25		30		35	30	ns
t <sub>PXZ</sub>	Input to output disable	C1 = 5 pF, <i>Note (4)</i>		25		30		35	30	ns
t <sub>CLR</sub>	Asynchronous output clear time	C1 = 35 pF		27		32		37	30	ns
f <sub>MAX</sub>	Maximum frequency	<i>Note (5)</i>	47.6		41.7		37		0	MHz
t <sub>SU</sub>	Global clock input setup time		21		24		27		30	ns
t <sub>H</sub>	Global clock input hold time		0		0		0		0	ns
t <sub>CH</sub>	Global clock high time		10		11		12		0	ns
t <sub>CL</sub>	Global clock low time		10		11		12		0	ns
t <sub>CO1</sub>	Global clock to output delay			15		17		20	0	ns
t <sub>CNT</sub>	Global clock minimum period			25		30		35	0	ns
f <sub>CNT</sub>	Max. internal global clock frequency	<i>Note (6)</i>	40		33.3		28.6		0	MHz
t <sub>ASU</sub>	Array clock input setup time		8		8		8		30	ns
t <sub>AH</sub>	Array clock input hold time		12		12		12		0	ns
t <sub>ACH</sub>	Array clock high time		10		11		12		0	ns
t <sub>ACL</sub>	Array clock low time		10		11		12		0	ns
t <sub>ODH</sub>	Output data hold time after clock	C1 = 35 pF, <i>Note (7)</i>	1		1		1			ns
t <sub>ACO1</sub>	Array clock to output delay			27		32		37	30	ns
t <sub>ACNT</sub>	Array clock minimum period			25		30		35	0	ns
f <sub>ACNT</sub>	Max. internal global clock frequency	<i>Note (6)</i>	40		33.3		28.6		0	MHz

<i>Internal Timing Parameters</i>			EP610-25		EP610-30		EP610-35		
Symbol	Parameter	Condition	Min	Max	Min	Max	Min	Max	Unit
$t_{IN}$	Input pad and buffer delay			8		9		11	ns
$t_{IO}$	I/O input pad and buffer delay			2		2		2	ns
$t_{LAD}$	Logic array delay			11		14		15	ns
$t_{OD}$	Output buffer and pad delay	C1 = 35 pF		6		7		9	ns
$t_{ZX}$	Output buffer enable delay	C1 = 35 pF		6		7		9	ns
$t_{XZ}$	Output buffer disable delay	C1 = 5 pF		6		7		9	ns
$t_{SU}$	Register setup time		11		11		12		ns
$t_H$	Register hold time		10		10		10		ns
$t_{IC}$	Array clock delay			13		16		17	ns
$t_{ICS}$	Global clock delay			1		1		0	ns
$t_{FD}$	Feedback delay			3		5		8	ns
$t_{CLR}$	Register clear time			13		16		17	ns

**Notes to tables:**

- (1) These values are specified under the “EP610 & EP610I Device Recommended Operating Conditions” on page 432.
- (2) See [Application Note 78 \(Understanding MAX 5000 & Classic Timing\)](#) in this data book for information on internal timing parameters.
- (3) The non-Turbo adder must be added to this parameter when the Turbo Bit option is off.
- (4) Sample-tested only for an output change of 500 mV.
- (5) The  $f_{MAX}$  values represent the highest frequency for pipelined data.
- (6) Measured with a device programmed as a 16-bit counter.
- (7) Sample-tested only. This parameter is a guideline based on extensive device characterization. This parameter applies for both global and array clocking.

EP610 Device AC Operating Conditions *Notes (1), (2)*

<i>External Timing Parameters</i>			EP610I-10		Non-Turbo Adder	
Symbol	Parameter	Conditions	Min	Max	<i>Note (3)</i>	Unit
t <sub>PD1</sub>	Input to non-registered output	C1 = 35 pF		10	25	ns
t <sub>PD2</sub>	I/O input to non-registered output			10	25	ns
t <sub>PZX</sub>	Input to output enable			15	25	ns
t <sub>PXZ</sub>	Input to output disable	C1 = 5 pF, <i>Note (4)</i>		13	25	ns
t <sub>CLR</sub>	Asynchronous output clear time	C1 = 35 pF		13	25	ns
f <sub>MAX</sub>	Maximum frequency	<i>Note (5)</i>	125		0	MHz
t <sub>SU</sub>	Global clock input setup time		7		25	ns
t <sub>H</sub>	Global clock input hold time		0		0	ns
t <sub>CH</sub>	Global clock high time		5		0	ns
t <sub>CL</sub>	Global clock low time		5		0	ns
t <sub>CO1</sub>	Global clock to output delay			6.5	0	ns
t <sub>CNT</sub>	Global clock minimum period			10	25	ns
f <sub>CNT</sub>	Maximum internal global clock frequency	<i>Note (6)</i>	100		0	MHz
t <sub>ASU</sub>	Array clock input setup time		1.5		25	ns
t <sub>AH</sub>	Array clock input hold time		5.5		0	ns
t <sub>ACH</sub>	Array clock high time		5		0	ns
t <sub>ACL</sub>	Array clock low time		5		0	ns
t <sub>ODH</sub>	Output data hold time after clock	C1 = 35 pF, <i>Note (7)</i>	1		0	ns
t <sub>ACO1</sub>	Array clock to output delay			12	25	ns
t <sub>ACNT</sub>	Array clock minimum period			10	25	ns
f <sub>ACNT</sub>	Max. internal array clock frequency	<i>Note (6)</i>	100		0	MHz

<i>Internal Timing Parameters</i>			EP610I-10		
Symbol	Parameter	Conditions	Min	Max	Unit
$t_{IN}$	Input pad and buffer delay			1.5	ns
$t_{IO}$	I/O input pad and buffer delay			0.0	ns
$t_{LAD}$	Logic array delay			5.5	ns
$t_{OD}$	Output buffer and pad delay	C1 = 35 pF		3.0	ns
$t_{ZX}$	Output buffer enable delay	C1 = 35 pF		8.0	ns
$t_{XZ}$	Output buffer disable delay	C1 = 5 pF		6.0	ns
$t_{SU}$	Register setup time		3.5		ns
$t_H$	Register hold time		3.5		ns
$t_{IC}$	Array clock delay			7.5	ns
$t_{ICS}$	Global clock delay			2.0	ns
$t_{FD}$	Feedback delay			1.0	ns
$t_{CLR}$	Register clear time			8.5	ns

**Notes to tables:**

- (1) These values are specified under the “EP610 & EP610I Device Recommended Operating Conditions” on page 432.
- (2) See *Application Note 78 (Understanding MAX 5000 & Classic Timing)* in this data book for more information on Classic timing parameters.
- (3) The non-Turbo adder must be added to this parameter when the Turbo Bit option is off.
- (4) Sample-tested only for an output change of 500 mV.
- (5) The  $f_{MAX}$  values represent the highest frequency for pipelined data.
- (6) Measured with a device programmed as a 16-bit counter.
- (7) Sample-tested only. This parameter is a guideline based on extensive device characterization. This parameter applies for both global and array clocking.



*Notes:*

## Features

- High-performance, 24-macrocell Classic EPLD
  - Combinatorial speeds with  $t_{PD}$  as fast as 12 ns
  - Counter frequencies of up to 76.9 MHz
  - Pipelined data rates of up to 125 MHz
- Programmable I/O architecture with up to 36 inputs or 24 outputs
- EP910 and EP910I devices that are pin-, function-, and programming file-compatible
- Programmable clock option for independent clocking of all registers
- Macrocells individually programmable as D, T, JK, or SR flipflops, or for combinatorial operation
- Available in the following packages (see Figure 11):
  - 44-pin plastic J-lead chip carrier (PLCC)
  - 40-pin ceramic and plastic dual in-line packages (CerDIP and PDIP)

Figure 11. EP910 Package Pin-Out Diagrams

Package outlines are not drawn to scale. Windows in ceramic packages only.

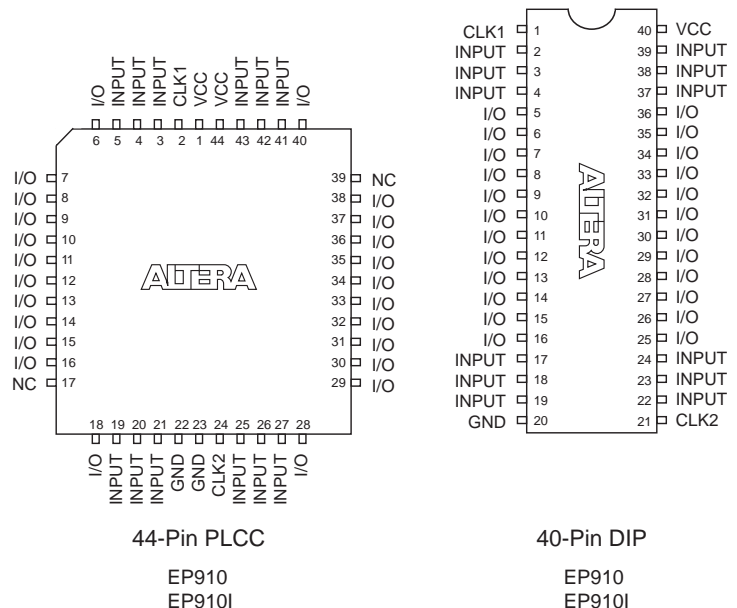

# General Description

Altera EP910 devices can implement up to 450 usable gates of small-scale integration (SSI) and medium-scale integration (MSI) logic functions. EP910 devices have 24 macrocells, 12 dedicated input pins, 24 I/O pins, and 2 global clock pins (see Figure 12). Each macrocell can access signals from the global bus, which consists of the true and complement forms of the dedicated inputs and the true and complement forms of either the output of the macrocell or the I/O input. The CLK1 and CLK2 signals are the dedicated clock inputs for the registers in macrocells 13 through 24 and 1 through 12, respectively.

Figure 12. EP910 Block Diagram

Numbers without parentheses are for DIP packages. Numbers in parentheses are for J-lead packages.

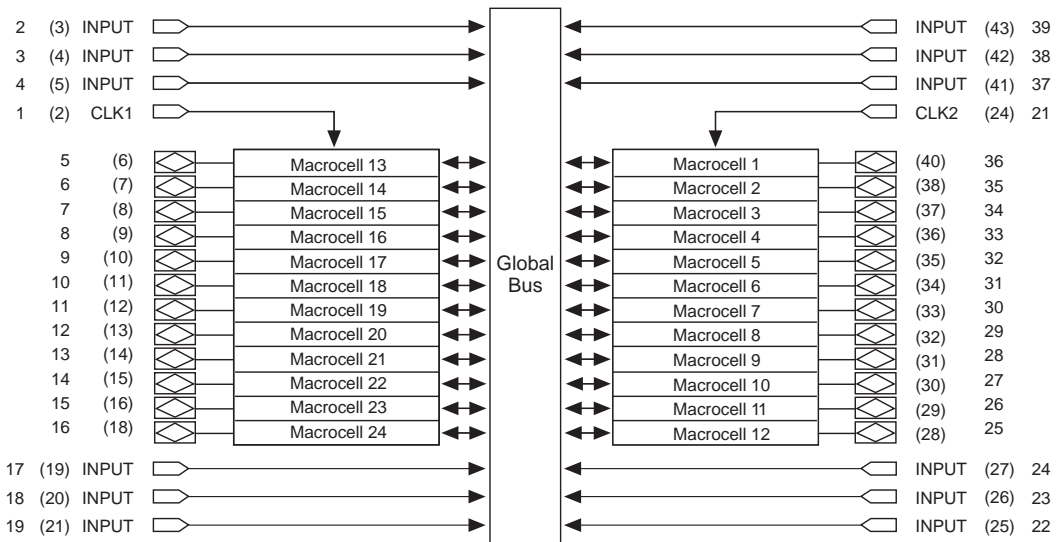

Figure 13 shows the typical supply current ( $I_{CC}$ ) versus frequency of EP910 devices.



Figure 13.  $I_{CC}$  vs. Frequency of EP910 Devices

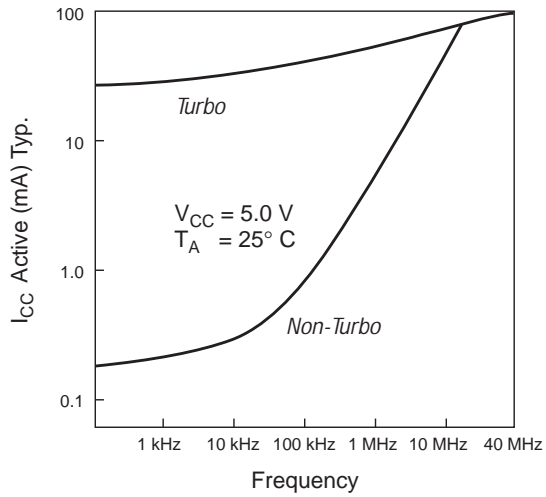
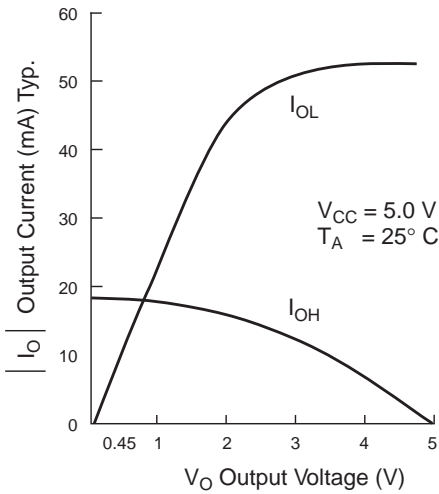

Figure 14 shows the typical output drive characteristics of EP910 devices.

Figure 14. Output Drive Characteristics of EP910 Devices

Drive characteristics may exceed shown curves.

EP910 EPLDs



EP910I EPLDs

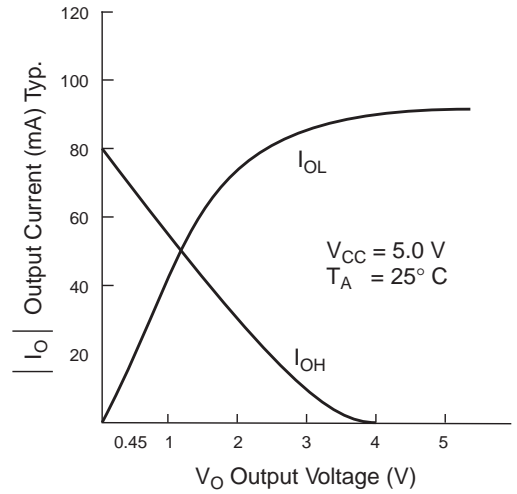

## Operating Conditions

The following tables provide information on absolute maximum ratings, recommended operating conditions, operating conditions, and capacitance for EP910 and EP910I devices.

### EP910 & EP910I Device Absolute Maximum Ratings *Note (1)*

			EP910		EP910I		
Symbol	Parameter	Conditions	Min	Max	Min	Max	Unit
V <sub>CC</sub>	Supply voltage	<i>Notes (2), (3)</i>	-2.0	7.0	-2.0	7.0	V
V <sub>I</sub>	DC input voltage	<i>Notes (2), (3)</i>	-2.0	7.0	-0.5	V <sub>CC</sub> + 0.5	V
I <sub>MAX</sub>	DC V <sub>CC</sub> or ground current		-250	250			mA
I <sub>OUT</sub>	DC output current, per pin		-25	25			mA
T <sub>STG</sub>	Storage temperature	No bias	-65	150	-65	150	° C
T <sub>AMB</sub>	Ambient temperature	<i>Note (4)</i>	-65	135	-10	85	° C
T <sub>J</sub>	Junction temperature	Ceramic packages, under bias		150		150	° C
		Plastic packages, under bias		135		135	° C

### EP910 & EP910I Device Recommended Operating Conditions *Note (5)*

			EP910		EP910I		
Symbol	Parameter	Conditions	Min	Max	Min	Max	Unit
V <sub>CC</sub>	Supply voltage	<i>Note (6)</i>	4.75 (4.5)	5.25 (5.5)	4.75	5.25	V
V <sub>I</sub>	Input voltage		0	V <sub>CC</sub>	0	V <sub>CC</sub>	V
V <sub>O</sub>	Output voltage		0	V <sub>CC</sub>	0	V <sub>CC</sub>	V
T <sub>A</sub>	Operating temperature	For commercial use	0	70	0	70	° C
		For industrial use	-40	85			° C
t <sub>R</sub>	Input rise time	<i>Note (7)</i>		100 (50)		500	ns
t <sub>F</sub>	Input fall time	<i>Note (7)</i>		100 (50)		500	ns

### EP910 & EP910I Device DC Operating Conditions *Notes (8), (9)*

Symbol	Parameter	Conditions	Min	Max	Unit
V <sub>IH</sub>	High-level input voltage		2.0	V <sub>CC</sub> + 0.3	V
V <sub>IL</sub>	Low-level input voltage		-0.3	0.8	V
V <sub>OH</sub>	High-level TTL output voltage	I <sub>OH</sub> = -4 mA DC, <i>Note (10)</i>		2.4	V
	High-level CMOS output voltage	I <sub>OH</sub> = 0.6 mA DC, <i>Notes (10), (11)</i>		3.84	V
V <sub>OL</sub>	Low-level output voltage	I <sub>OL</sub> = 4 mA DC, <i>Note (10)</i>		0.45	V
I <sub>I</sub>	I/O leakage current of dedicated input pins	V <sub>I</sub> = V <sub>CC</sub> or ground	-10	10	μA
I <sub>OZ</sub>	Tri-state output leakage current	V <sub>O</sub> = V <sub>CC</sub> or ground	-10	10	μA

## EP910 &amp; EP910I Device Capacitance Notes (8), (12)

			EP910		EP910I		
Symbol	Parameter	Conditions	Min	Max	Min	Max	Unit
$C_{IN}$	Input pin capacitance	$V_{IN} = 0\text{ V}$ , $f = 1.0\text{ MHz}$		20		8	pF
$C_{I/O}$	I/O pin capacitance	$V_{OUT} = 0\text{ V}$ , $f = 1.0\text{ MHz}$		20		8	pF
$C_{CLK1}$	CLK1 pin capacitance	$V_{IN} = 0\text{ V}$ , $f = 1.0\text{ MHz}$		20		10	pF
$C_{CLK2}$	CLK2 pin capacitance	$V_{IN} = 0\text{ V}$ , $f = 1.0\text{ MHz}$		20		12	pF

 EP910 & EP910I Device  $I_{CC}$  Supply Current Notes (5), (8), (9)

			EP910			EP910I			
Symbol	Parameter	Conditions	Min	Typ	Max	Min	Typ	Max	Unit
$I_{CC1}$	$V_{CC}$ supply current (non-Turbo, standby)	$V_I = V_{CC}$ or ground, no load, Notes (13), (14)		20	150		60	150	$\mu\text{A}$
$I_{CC2}$	$V_{CC}$ supply current (non-Turbo, active)	$V_I = V_{CC}$ or ground, no load, $f = 1.0\text{ MHz}$ , Notes (13), (14)		6	20		4	12	mA
$I_{CC3}$	$V_{CC}$ supply current (Turbo, active)	$V_I = V_{CC}$ or ground, no load, $f = 1.0\text{ MHz}$ , Note (14)		45	80 (100)		120	150	mA

**Notes to tables:**

- (1) See the [Operating Requirements for Altera Devices Data Sheet](#) in this data book.
- (2) Voltage with respect to ground.
- (3) For EP910 devices, the minimum DC input is  $-0.3\text{ V}$ ; for EP910I devices, the minimum DC input is  $-0.5\text{ V}$ . During transitions, the inputs may undershoot to  $-2.0\text{ V}$  or overshoot to  $7.0\text{ V}$  for periods less than  $20\text{ ns}$  under no-load conditions.
- (4) Under bias. Extended temperature versions are also available.
- (5) Numbers in parentheses are for industrial-temperature-range devices.
- (6) Maximum  $V_{CC}$  rise time for EP910 devices =  $50\text{ ms}$ ; for EP910I devices, maximum  $V_{CC}$  rise time is unlimited with monotonic rise.
- (7) For all clocks:  $t_R$  and  $t_F = 100\text{ ns}$  ( $50\text{ ns}$  for the industrial-temperature-range version).
- (8) These values are specified under the [“EP910 & EP910I Device Recommended Operating Conditions”](#) on page 444.
- (9) Typical values are  $T_A = 25^\circ\text{ C}$  and  $V_{CC} = 5\text{ V}$ .
- (10) The  $I_{OH}$  parameter refers to high-level TTL or CMOS output current; the  $I_{OL}$  parameter refers to low-level TTL output current.
- (11) This parameter does not apply to EP910I devices.
- (12) For EP910 devices: capacitance measured at  $25^\circ\text{ C}$ ; sample-tested devices only; clock-pin capacitance for dedicated clock inputs only; pin 21 (high-voltage pin during programming) has a maximum capacitance of  $60\text{ pF}$ . Values for EP910I devices are evaluated during initial characterization and design modifications.
- (13) When the Turbo Bit option is not set (non-Turbo mode), an EP910 device will enter standby mode if no logic transitions occur for  $100\text{ ns}$  after the last transition, and an EP910I device will enter standby mode if no logic transitions occur for  $75\text{ ns}$  after the last transition.
- (14) Measured with a device programmed as a 24-bit counter.

EP910 Device AC Operating Conditions *Notes (1), (2)*

<i>External Timing Parameters</i>			EP910-30		EP910-35		EP910-40		Non-Turbo Adder	
Symbol	Parameter	Conditions	Min	Max	Min	Max	Min	Max	<i>Note (3)</i>	Unit
t <sub>PD1</sub>	Input to non-registered output	C1 = 35 pF		30		35		40	30	ns
t <sub>PD2</sub>	I/O input to non-registered output	C1 = 35 pF		33		38		43	30	ns
t <sub>PZX</sub>	Input to output enable	C1 = 35 pF		30		35		40	30	ns
t <sub>PXZ</sub>	Input to output disable	C1 = 5 pF, <i>Note (4)</i>		30		35		40	30	ns
t <sub>CLR</sub>	Asynchronous output clear time	C1 = 35 pF		33		38		43	30	ns
f <sub>MAX</sub>	Maximum frequency	<i>Note (5)</i>	41.7		37		32.3		0	MHz
t <sub>SU</sub>	Global clock input setup time		24		27		31		30	ns
t <sub>H</sub>	Global clock input hold time		0		0		0		0	ns
t <sub>CH</sub>	Global clock high time		12		13		15		0	ns
t <sub>CL</sub>	Global clock low time		12		13		15		0	ns
t <sub>CO1</sub>	Global clock to output delay	C1 = 35 pF		18		21		24	0	ns
t <sub>CNT</sub>	Global clock minimum clock period	<i>Note (6)</i>		30		35		40	0	ns
f <sub>CNT</sub>	Maximum internal global clock frequency	<i>Note (6)</i>	33.3		28.6		25		0	MHz
t <sub>ASU</sub>	Array clock input setup time		10		10		10		30	ns
t <sub>AH</sub>	Array clock input hold time		15		15		15		0	ns
t <sub>ACH</sub>	Array clock high time		15		16		17		0	ns
t <sub>ACL</sub>	Array clock low time		15		16		17		0	ns
t <sub>ODH</sub>	Output data hold time after clock	C1 = 35 pF, <i>Note (7)</i>	1		1		1			ns
t <sub>ACO1</sub>	Array clock to output delay	C1 = 35 pF		33		38		43	30	ns
t <sub>ACNT</sub>	Array clock minimum clock period			30		35		40	0	ns
f <sub>ACNT</sub>	Max. internal array clock frequency	<i>Note (6)</i>	33.3		28.6		25		0	MHz

<i>Internal Timing Parameters</i>			EP910-30		EP910-35		EP910-40		
Symbol	Parameter	Condition	Min	Max	Min	Max	Min	Max	Unit
$t_{IN}$	Input pad and buffer delay			9		10		13	ns
$t_{IO}$	I/O input pad and buffer delay			3		3		3	ns
$t_{LAD}$	Logic array delay			14		16		17	ns
$t_{OD}$	Output buffer and pad delay	C1 = 35 pF		7		9		10	ns
$t_{ZX}$	Output buffer enable delay	C1 = 35 pF		7		9		10	ns
$t_{XZ}$	Output buffer disable delay	C1 = 5 pF		7		9		10	ns
$t_{SU}$	Register setup time		12		13		15		ns
$t_H$	Register hold time		12		12		12		ns
$t_{IC}$	Array clock delay			17		19		20	ns
$t_{ICS}$	Global clock delay			2		2		1	ns
$t_{FD}$	Feedback delay			4		6		8	ns
$t_{CLR}$	Register clear time			17		19		20	ns

**Notes to tables:**

- (1) These values are specified under the “EP910 & EP910I Device Recommended Operating Conditions” on page 444.
- (2) See *Application Note 78 (Understanding MAX 5000 & Classic Timing)* for more information on Classic timing parameters.
- (3) The non-Turbo adder must be added to this parameter when the Turbo Bit option is off.
- (4) Sample-tested only for an output change of 500 mV.
- (5) The  $f_{MAX}$  values represent the highest frequency for pipelined data.
- (6) Measured with a device programmed as a 24-bit counter.
- (7) Sample-tested only. This parameter is a guideline based on extensive device characterization and applies for both global and array clocking.

EP910I Device AC Operating Conditions Notes (1), (2)

External Timing Parameters			EP910I-12		EP910I-15		EP910I-25		Non-Turbo Adder	
Symbol	Parameter	Conditions	Min	Max	Min	Max	Min	Max	Note (3)	Unit
t <sub>PD1</sub>	Input to non-registered output	C1 = 35 pF		12		15		25	40	ns
t <sub>PD2</sub>	I/O input to non-registered output	C1 = 35 pF		12		15		25	40	ns
t <sub>PZX</sub>	Input to output enable	C1 = 35 pF		15		18		28	40	ns
t <sub>PXZ</sub>	Input to output disable	C1 = 35 pF, Note (4)		15		18		28	40	ns
t <sub>CLR</sub>	Asynchronous output clear time	C1 = 35 pF		15		18		28	40	ns
f <sub>MAX</sub>	Global clock maximum frequency	Note (5)	125		100		62.5		0	MHz
t <sub>SU</sub>	Global clock input setup time		8		11		16		40	ns
t <sub>H</sub>	Global clock input hold time		0		0		0		0	ns
t <sub>CH</sub>	Global clock high time		5		6		10		0	ns
t <sub>CL</sub>	Global clock low time		5		6		10		0	ns
t <sub>CO1</sub>	Global clock to output delay			8		9		14	0	ns
t <sub>CNT</sub>	Global clock minimum clock period	C1 = 35 pF		13		15		25	40	ns
f <sub>CNT</sub>	Maximum internal global clock frequency	Note (6)	76.9		66.6		40		0	MHz
t <sub>ASU</sub>	Array clock input setup time		0		2		8		40	ns
t <sub>AH</sub>	Array clock input hold time		8		9		8			ns
t <sub>ACH</sub>	Array clock high time		6		7.5		12.5			ns
t <sub>ACL</sub>	Array clock low time		6		7.5		12.5			ns
t <sub>ODH</sub>	Output data hold time after clock	C1 = 35 pF, Note (7)	1		1		1			ns
t <sub>ACO1</sub>	Array clock to output delay	C1 = 35 pF		16		18		22	40	ns
t <sub>ACNT</sub>	Array clock minimum clock period			13		15		25	40	ns
f <sub>ACNT</sub>	Maximum internal array clock frequency	Note (6)	76.9		66.6		40			MHz

<i>Internal Timing Parameters</i>			EP910I-12		EP910I-15		EP910I-25		
Symbol	Parameter	Condition	Min	Max	Min	Max	Min	Max	Unit
$t_{IN}$	Input pad and buffer delay			2		3		2	ns
$t_{IO}$	I/O input pad and buffer delay			0		0		0	ns
$t_{LAD}$	Logic array delay			8		9		17	ns
$t_{OD}$	Output buffer and pad delay	C1 = 35 pF		2		3		6	ns
$t_{ZX}$	Output buffer enable delay	C1 = 35 pF		5		6		9	ns
$t_{XZ}$	Output buffer disable delay	C1 = 5 pF		5		6		9	ns
$t_{SU}$	Register setup time		4		5		5		ns
$t_H$	Register hold time		4		6		11		ns
$t_{IC}$	Array clock delay			12		12		14	ns
$t_{ICS}$	Global clock delay			4		3		6	ns
$t_{FD}$	Feedback delay			1		1		3	ns
$t_{CLR}$	Register clear time			11		12		20	ns

**Notes to tables:**

- (1) These values are specified under the “EP910 & EP910I Device Recommended Operating Conditions” on page 444.
- (2) See [Application Note 78 \(Understanding MAX 5000 & Classic Timing\)](#) in this data book for information on internal timing parameters.
- (3) The non-Turbo adder must be added to this parameter when the Turbo Bit option is off.
- (4) Sample-tested only for an output change of 500 mV.
- (5) The  $f_{MAX}$  values represent the highest frequency for pipelined data.
- (6) Measured with the device programmed as a 24-bit counter.
- (7) Sample-tested only. This parameter is a guideline based on extensive device characterization and applies for both global and array clocking.



*Notes:*



## Features

- High-performance, 48-macrocell Classic EPLD
  - Combinatorial speeds with  $t_{PD}$  as fast as 20 ns
  - Counter frequencies of up to 50 MHz
  - Pipelined data rates of up to 62.5 MHz
- Programmable I/O architecture with up to 64 inputs or 48 outputs
- Programmable clock option for independent clocking of all registers
- Macrocells individually programmable as D, T, JK, or SR flipflops, or for combinatorial operation
- Available in the following packages (see [Figure 15](#))
  - 68-pin ceramic pin-grid array (PGA)
  - 68-pin plastic J-lead chip carrier (PLCC)

Figure 15. EP1810 Package Pin-Out Diagrams

Package outlines not drawn to scale. See [Table 2 on page 459](#) of this data sheet for PGA package pin-out information. Windows in ceramic packages only.

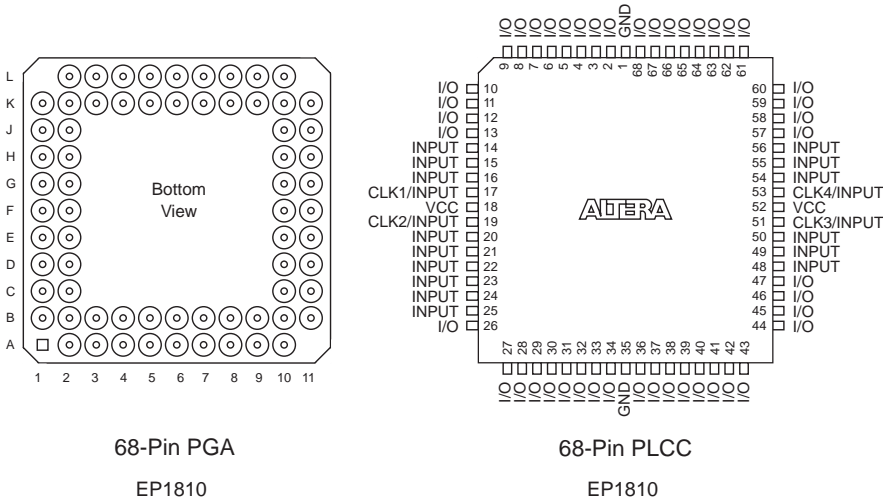

## General Description

Altera EP1810 devices offer large-scale integration (LSI) density, TTL-equivalent speed, and low-power consumption. EP1810 devices have 48 macrocells, 16 dedicated input pins, and 48 I/O pins (see [Figure 16](#)). EP1810 devices are divided into four quadrants, each containing 12 macrocells. Of the 12 macrocells in each quadrant, 8 have quadrant feedback and are “local” macrocells (see [“Feedback Select” on page 423](#) of this data sheet for more information). The remaining 4 macrocells in the quadrant are “global” macrocells. Both local and global macrocells can access signals from the global bus, which consists of the true and complement forms of the dedicated inputs and the true and complement forms of the feedbacks from the global macrocells.

EP1810 devices also have four dedicated inputs (one in each quadrant) that can be used as quadrant clock inputs. If the dedicated input is used as a clock pin, the input feeds the clock input of all registers in that particular quadrant.

Figure 16. EP1810 Block Diagram

Numbers without parentheses are for J-lead packages. Numbers with parentheses are for PGA packages.

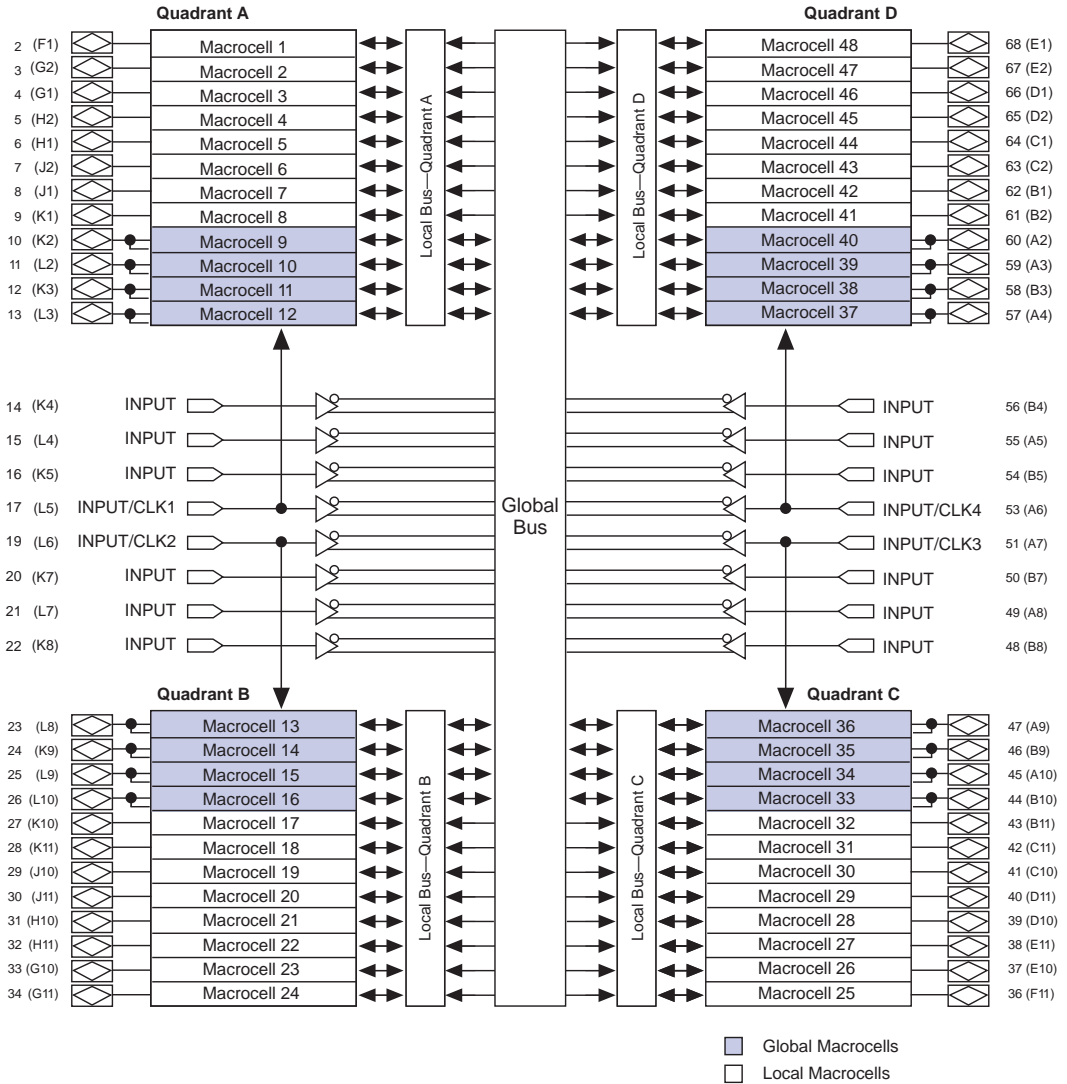

Figure 17 shows the typical supply current ( $I_{CC}$ ) versus frequency for EP1810 EPLDs.

Figure 17.  $I_{CC}$  vs. Frequency of EP1810 Devices

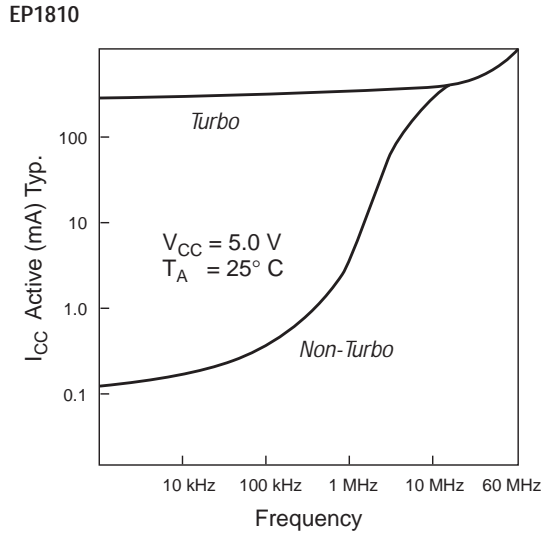
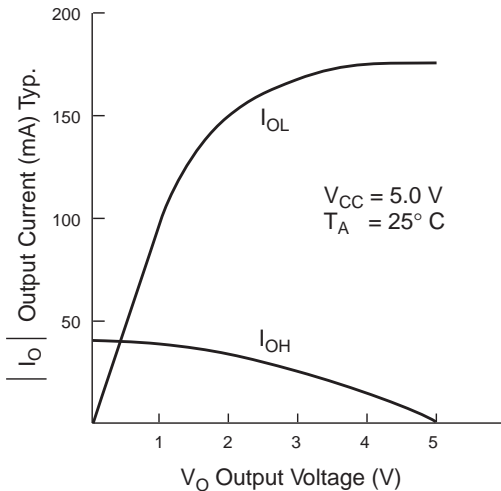

Figure 18 shows the output drive characteristics of EP1810 devices.

Figure 18. Output Drive Characteristics of EP1810 Devices

Drive characteristics may exceed shown curves.

EP1810-20 & EP1810-25 EPLDs



EP1810-35 & EP1810-45 EPLDs

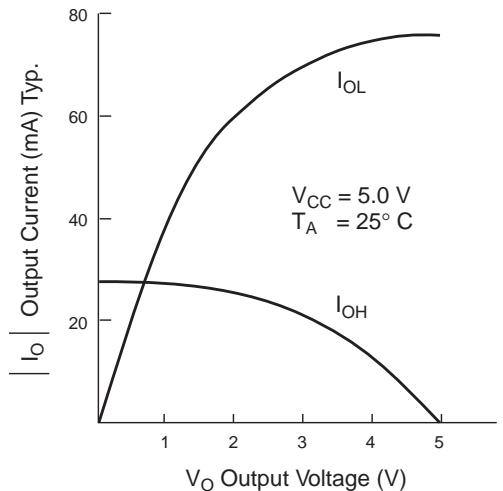

## Operating Conditions

The following tables provide information on absolute maximum ratings, recommended operating conditions, operating conditions, and capacitance for EP1810 devices.

### EP1810 Device Absolute Maximum Ratings *Notes (1), (2)*

Symbol	Parameter	Conditions	Min	Max	Unit
$V_{CC}$	Supply voltage	With respect to ground, <i>Note (3)</i>	-2.0 (-0.5)	7.0	V
$V_I$	DC input voltage	With respect to ground, <i>Note (3)</i>	-2.0 (-0.5)	7.0	V
$I_{MAX}$	DC $V_{CC}$ or ground current		-300 (-400)	300 (400)	mA
$I_{OUT}$	DC output current, per pin		-25	25	mA
$T_{STG}$	Storage temperature	No bias	-65	150	°C
$T_{AMB}$	Ambient temperature	Under bias	-65 (-55)	135 (125)	°C
$T_J$	Junction temperature	Under bias		(150)	°C

### EP1810 Device Recommended Operating Conditions *Note (2)*

Symbol	Parameter	Conditions	Min	Max	Unit
$V_{CC}$	Supply voltage	<i>Note (4)</i>	4.75 (4.5)	5.25 (5.5)	V
$V_I$	Input voltage		0	$V_{CC}$	V
$V_O$	Output voltage		0	$V_{CC}$	V
$T_A$	Operating temperature	For commercial use	0	70	°C
		For industrial use	-40	85	°C
$t_R$	Input rise time	<i>Note (5)</i>		50	ns
$t_F$	Input fall time	<i>Note (5)</i>		50	ns

### EP1810 Device DC Operating Conditions *Notes (6), (7)*

Symbol	Parameter	Conditions	Min	Max	Unit
$V_{IH}$	High-level input voltage		2.0	$V_{CC} + 0.3$	V
$V_{IL}$	Low-level input voltage		-0.3	0.8	V
$V_{OH}$	High-level TTL output voltage	$I_{OH} = -4$ mA DC, <i>Note (8)</i>	2.4		V
	High-level CMOS output voltage	$I_{OH} = 0.6$ mA DC, <i>Note (8)</i>	3.84		V
$V_{OL}$	Low-level output voltage	$I_{OL} = 4$ mA DC, <i>Note (8)</i>		0.45	V
$I_I$	I/O pin leakage current of dedicated input pins	$V_I = V_{CC}$ or ground	-10	10	$\mu$ A
$I_{OZ}$	Tri-state output leakage current	$V_O = V_{CC}$ or ground	-10	10	$\mu$ A

EP1810 Device Capacitance *Note (9)*

Symbol	Parameter	Conditions	Min	Max	Unit
C <sub>IN</sub>	Input pin capacitance	V <sub>IN</sub> = 0 V, f = 1.0 MHz		20	pF
C <sub>IO</sub>	I/O pin capacitance	V <sub>OUT</sub> = 0 V, f = 1.0 MHz		20	pF
C <sub>CLK</sub>	Clock pin capacitance	V <sub>IN</sub> = 0 V, f = 1.0 MHz		25	pF

EP1810 Device I<sub>CC</sub> Supply Current *Notes (2), (6), (7)*

				EP1810			
Symbol	Parameter	Conditions	Speed Grade	Min	Typ	Max	Unit
I <sub>CC1</sub>	V <sub>CC</sub> supply current (non-Turbo, standby)	V <sub>I</sub> = V <sub>CC</sub> or ground, no load, <i>Note (10)</i>	-20, -25	50	150	μA	
			-35, -45	35	150	μA	
I <sub>CC2</sub>	V <sub>CC</sub> supply current (non-Turbo, active)	V <sub>I</sub> = V <sub>CC</sub> or ground, no load, f = 1.0 MHz, <i>Note (10)</i>	-20, -25	20	40	mA	
			-35, -45	10	30 (40)	mA	
I <sub>CC3</sub>	V <sub>CC</sub> supply current (Turbo, active)	V <sub>I</sub> = V <sub>CC</sub> or ground, no load f = 1.0 MHz, <i>Note (10)</i>	-20, -25	180	225 (250)	mA	
			-35, -45	100	180 (240)	mA	

**Notes to tables:**

- (1) See the *Operating Requirements for Altera Devices Data Sheet* in this data book.
- (2) Numbers in parentheses are for industrial-temperature-range devices.
- (3) The minimum DC input is -0.3 V. During transitions, the inputs may undershoot to -2.0 V or overshoot to 7.0 V for periods less than 20 ns under no-load conditions.
- (4) Maximum V<sub>CC</sub> rise time is 50 ms.
- (5) For EP1810 clocks: t<sub>R</sub> and t<sub>F</sub> = 100 ns (50 ns for industrial-temperature-range versions).
- (6) Typical values are for T<sub>A</sub> = 25° C and V<sub>CC</sub> = 5 V.
- (7) These values are specified under the “EP1810 Device Recommended Operating Conditions” on page 455.
- (8) The I<sub>OH</sub> parameter refers to high-level TTL or CMOS output current; the I<sub>OL</sub> parameter refers to low-level TTL output current.
- (9) Capacitance measured at 25° C. Sample-tested only. Clock-pin capacitance for dedicated clock inputs only. Pin 19 has a maximum capacitance of 160 pF.
- (10) Measured with a device programmed as four 12-bit counters.

EP1810-20 & EP1810-25 AC Device Operating Conditions *Note (1)*

<i>External Timing Parameters</i>			EP1810-20		EP1810-25		Non-Turbo Adder	
Symbol	Parameter	Conditions	Min	Max	Min	Max	<i>Note (2)</i>	Unit
$t_{PD1}$	Input to non-registered output	C1 = 35 pF		20		25	25	ns
$t_{PD2}$	I/O input to non-registered output	C1 = 35 pF		22		28	25	ns
$t_{SU}$	Global clock setup time		13		17		25	ns
$t_H$	Global clock hold time		0		0		0	ns
$t_{CH}$	Global clock high time		8		10		0	ns
$t_{CL}$	Global clock low time		8		10		0	ns
$t_{CO1}$	Global clock to output delay	C1 = 35 pF		15		18	0	ns
$t_{CNT}$	Minimum global clock period	<i>Note (3)</i>		20		25	0	ns
$f_{CNT}$	Maximum internal frequency	<i>Note (3)</i>	50		40		0	MHz
$t_{ASU}$	Array clock setup time		8		10		25	ns
$t_{AH}$	Array clock hold time		8		10		0	ns
$t_{ACO1}$	Array clock to output delay	C1 = 35 pF		20		25	25	ns
$t_{ODH}$	Output data hold time after clock	C1 = 35 pF, <i>Note (4)</i>	1		1		0	ns
$t_{ACNT}$	Array clock maximum clock period	<i>Note (3)</i>		20		25	0	ns
$f_{ACNT}$	Maximum internal array clock frequency	<i>Note (3)</i>	50		40		0	ns
$f_{MAX}$	Maximum clock frequency	<i>Note (5)</i>	62.5		50		0	MHz

<i>Internal Timing Parameters</i>			EP1810-20		EP1810-25		Non-Turbo Adder	
Symbol	Parameter	Conditions	Min	Max	Min	Max	<i>Note (2)</i>	Unit
$t_{IN}$	Input pad and buffer delay			5		7	0	ns
$t_{IO}$	I/O input pad and buffer delay			2		3	0	ns
$t_{LAD}$	Logic array delay			9		12	25	ns
$t_{OD}$	Output buffer and pad delay	C1 = 35 pF		6		6	0	ns
$t_{ZX}$	Output buffer enable delay	C1 = 35 pF		6		6	0	ns
$t_{XZ}$	Output buffer disable delay	C1 = 5 pF, <i>Note (6)</i>		6		6	0	ns
$t_{SU}$	Register setup time		8		10		0	ns
$t_H$	Register hold time		5		10		0	ns
$t_{IC}$	Array clock delay			9		12	25	ns
$t_{ICS}$	Global clock delay			4		5	0	ns
$t_{FD}$	Feedback delay			3		3	-25	ns
$t_{CLR}$	Register clear time			9		12	25	ns

EP1810-35 & EP1810-45 Device AC Operating Conditions *Note (1)*

<i>External Timing Parameters</i>			EP1810-35		EP1810-45		Non-Turbo Adder	
Symbol	Parameter	Conditions	Min	Max	Min	Max	<i>Note (2)</i>	Unit
$t_{PD1}$	Input to non-registered output	C1 = 35 pF		35		45	30	ns
$t_{PD2}$	I/O input to non-registered output	C1 = 35 pF		40		50	30	ns
$t_{SU}$	Global clock setup time		25		30		30	ns
$t_H$	Global clock hold time		0		0		0	ns
$t_{CH}$	Global clock high time		12		15		0	ns
$t_{CL}$	Global clock low time		12		15		0	ns
$t_{CO1}$	Global clock to output delay	C1 = 35 pF		20		25	0	ns
$t_{CNT}$	Minimum global clock period	<i>Note (3)</i>		35		45	0	ns
$f_{CNT}$	Maximum internal frequency	<i>Note (3)</i>	28.6		22.2		0	MHz
$t_{ASU}$	Array clock setup time		10		11		30	ns
$t_{AH}$	Array clock hold time		15		18		0	ns
$t_{ACO1}$	Array clock to output delay	C1 = 35 pF		35		45	30	ns
$t_{ODH}$	Output data hold time after clock	C1 = 35 pF, <i>Note (4)</i>	1		1			ns
$t_{ACNT}$	Array clock maximum clock period	<i>Note (3)</i>		35		45	0	ns
$f_{ACNT}$	Maximum internal array clock frequency	<i>Note (3)</i>	28.6		22.2		0	ns
$f_{MAX}$	Maximum clock frequency	<i>Note (5)</i>	40		33.3		0	MHz

<i>Internal Timing Parameters</i>			EP1810-35		EP1810-45		Non-Turbo Adder	
Symbol	Parameter	Conditions	Min	Max	Min	Max	<i>Note (2)</i>	Unit
$t_{IN}$	Input pad and buffer delay			7		6	0	ns
$t_{IO}$	I/O input pad and buffer delay			5		5	0	ns
$t_{LAD}$	Logic array delay			19		28	30	ns
$t_{OD}$	Output buffer and pad delay	C1 = 35 pF		9		11	0	ns
$t_{ZX}$	Output buffer enable delay	C1 = 35 pF		9		11	0	ns
$t_{XZ}$	Output buffer disable delay	C1 = 5 pF, <i>Note (6)</i>		9		11	0	ns
$t_{SU}$	Register setup time		10		10		0	ns
$t_H$	Register hold time		15		18		0	ns
$t_{IC}$	Array clock delay			19		28	30	ns
$t_{ICS}$	Global clock delay			4		8	0	ns
$t_{FD}$	Feedback delay			6		7	-30	ns
$t_{CLR}$	Register clear time			24		32	30	ns



**Notes to tables:**

- (1) These values are specified under the “EP1810 Device Recommended Operating Conditions” on page 455.
- (2) The non-Turbo adder must be added to this parameter when the Turbo Bit option is off.
- (3) Measured with a device programmed as four 12-bit counters.
- (4) Sample-tested only. This parameter is a guideline based on extensive device characterization. This parameter applies for both global and array clocking.
- (5) The  $f_{MAX}$  values represent the highest frequency for pipelined data.
- (6) Sample-tested only for an output change of 500 mV.

## Pin-Out Information

Table 2 provides pin-out information for EP1810 devices in 68-pin PGA packages.

Pin	Function	Pin	Function	Pin	Function	Pin	Function
A2	I/O	B9	I/O	F10	GND	K4	INPUT
A3	I/O	B10	I/O	F11	I/O	K5	INPUT
A4	I/O	B11	I/O	G1	I/O	K6	VCC
A5	INPUT	C1	I/O	G2	I/O	K7	INPUT
A6	CLK4/INPUT	C2	I/O	G10	I/O	K8	INPUT
A7	CLK3/INPUT	C10	I/O	G11	I/O	K9	I/O
A8	INPUT	C11	I/O	H1	I/O	K10	I/O
A9	I/O	D1	I/O	H2	I/O	K11	I/O
A10	I/O	D2	I/O	H10	I/O	L2	I/O
B1	I/O	D10	I/O	H11	I/O	L3	I/O
B2	I/O	D11	I/O	J1	I/O	L4	INPUT
B3	I/O	E1	I/O	J2	I/O	L5	CLK1/INPUT
B4	INPUT	E2	I/O	J10	I/O	L6	CLK2/INPUT
B5	INPUT	E10	I/O	J11	I/O	L7	INPUT
B6	VCC	E11	I/O	K1	I/O	L8	I/O
B7	INPUT	F1	I/O	K2	I/O	L9	I/O
B8	INPUT	F2	GND	K3	I/O	L10	I/O

Copyright © 1995, 1996, 1997, 1998 Altera Corporation, 101 Innovation Drive, San Jose, CA 95134, USA, all rights reserved.

By accessing this information, you agree to be bound by the terms of Altera's Legal Notice.